

A telemedicine instrument for home monitoring of patients with chronic respiratory diseases

Andrea Tura^(a), Paolo Santini^(b), David Longo^(b) and Luca Quareni^(b)

^(a)Istituto di Ingegneria Biomedica, Consiglio Nazionale delle Ricerche, Padova, Italy

^(b)QBGROUP Spa, Padova, Italy

Summary. We developed a telemedicine instrument for home monitoring of subjects with respiratory diseases. The instrument directly measures blood oxygen saturation and pulse rate, but the most relevant aspect is that it also acts as digital recorder of parameters coming from several external instruments (spirometer, capnometer, NIBP device, etc.). It also connects to all pulmonary ventilators. The instrument main board includes five slots, which are used to insert the measuring boards (saturation and ventilation boards) and the interface boards (connecting the external instruments). Depending on patient's needs, only the proper measuring/interface boards are mounted, thus allowing maximum flexibility and cost saving. The instrument has several I/O units, and especially an internal modem for direct connection to the Internet through TCP/IP protocol. The instrument was extensively tested, and preliminary trials were performed over fifteen patients with amyotrophic lateral sclerosis.

Keywords: medical device, telemonitoring, telecare, Internet, pneumology.

Riassunto (*Uno strumento di telemedicina per monitoraggio domiciliare di soggetti con patologie respiratorie*). È stato sviluppato uno strumento di telemedicina per monitoraggio domiciliare di soggetti con patologie respiratorie. Lo strumento misura direttamente la saturazione dell'ossigeno nel sangue e la frequenza del polso, ma l'aspetto più rilevante è che funziona anche come registratore digitale di parametri provenienti da diversi strumenti esterni (spirometro, capnometro, dispositivo per misura di pressione sanguigna, ecc.). Si collega inoltre a tutti i ventilatori polmonari. La piastra principale dello strumento include cinque slot, che sono usati per inserire le schede di misura (schede di saturazione e di ventilazione) e le schede di interfaccia (per collegamento agli strumenti esterni). In base alle necessità del paziente, sono montate solo le schede di misura/interfaccia opportune, permettendo così la massima flessibilità e il massimo risparmio. Lo strumento è dotato di diverse unità di I/O, ed in particolare di un modem interno per connessione diretta ad Internet attraverso il protocollo TCP/IP. Lo strumento è stato testato in maniera estensiva, e uno studio clinico preliminare è stato compiuto su quindici pazienti con sclerosi laterale amiotrofica.

Parole chiave: dispositivo medico, telemonitoraggio, teleassistenza, Internet, pneumologia.

INTRODUCTION

In recent years, strong evidence has grown up regarding the convenience of telemedicine solutions in several contexts [1]. The efficacy of many telemedicine systems was proved in terms both of clinical goals achieved and of economical factors [2]. Due to the dramatic progress and concomitant decrease in costs of electronics and telematics [3], several individuals have gained access to efficient, even wireless, communication solutions [4]. For this reason, a strong increase has become possible in a specific telemedicine area, which is telemonitoring outside the hospital, i.e. at patient's home or very close to it [5-7].

Typically, home monitoring is adequate for chronic diseases, which require long term health care activi-

ties. Among these diseases, some are those related with respiratory problems, such as asthma or obstructive pathologies [8-10].

The medical instrument that we have recently developed relies in fact in the field of home monitoring of patients with chronic respiratory diseases. It is able to measure or collect several parameters of clinical relevance, such as: i) blood oxygen saturation and pulse rate; ii) oxygen level in the O₂ unit; iii) parameters coming from external instruments: the most relevant are a spirometer, a capnometer, and a non-invasive blood pressure measuring device; iv) parameters from pulmonary ventilators, also without any digital port for communication (old type ventilators). At prescribed time intervals, all

the stored data are then transmitted to a Web server directly through the Internet.

MATERIALS AND METHODS

Architecture of the medical instrument

The general architecture of the instrument is reported in *Figure 1*. The instrument is made of a main board, including the main CPU and related electronic components, and of several electronic units for the I/O functionalities of the instrument. Moreover, the main board has five slots, which allow insertion of five different electronic boards for parameter measuring or interfacing to the external instruments. This solution allows great flexibility and modularity: in fact, only the electronic boards necessary for the specific patient can be mounted, depending on the external instruments that the patient is connected to.

Main CPU

The main CPU is based on the Rabbit 3000 microprocessor. This microprocessor has an instruction set similar to that of traditional microprocessors (such as Z80/Z180), but with improvements that facilitate development in C language. Rabbit 3000 is also equipped with several peripherals on-board (both serial and parallel ports, timers, real time clock, interface of “glueless” type to memory and to I/O devices).

Some components are directly connected to the main CPU: a 512 KB Flash chip for the firmware of the instrument, a 512 KB SRAM chip for storage of variables during firmware execution, the backup battery and the CPU supervisor, which acts as CPU watchdog, and possibly commutes between the normal power supply line and the backup battery.

Modem

The instrument is equipped with an internal modem, which allows direct access to the Internet through

TCP/IP protocol, included in the main CPU firmware. The integration of the modem inside the instrument allows saving space at the patient’s home. The modem module matches all the requirements in terms of safety and of electromagnetic compatibility. Communication rate can reach 56 kbps. Other components are also part of the modem unit, for protection against peaks of current and of voltage (TVS diodes, one restorable fuse, and one varistor). It is also worth noting that for safety reasons the modem unit is electrically insulated from the external telephone line.

Ethernet interface

The core of the Ethernet interface is a controller produced by Realtek with full-duplex functionality: it allows contemporary reception and transmission over a connection to an Ethernet hub. It supports three types of Ethernet networks: 10 Base-T, 10 Base-2, 10 Base-5. For the physical connection to the Ethernet, the instrument is equipped with a special connector of RJ45 type, which also includes a filter for EMI reduction, and a separation block. Inclusion of these blocks already in the RJ45 connector allows saving space on the main board.

USB interface

It is based on an USB port controller, which implements the whole USB stack. It works both with USB 1.1 and 2.0 format. An USB filter is also included, located between the port controller and the physical port connector, thus allowing ESD protection and EMI reduction: problems of interference are common on high speed lines (up to 12 Mbit per second) like those in a USB port. Moreover, a small EEPROM has been inserted, to store the Vendor ID and the Product ID, that each USB device must be equipped with. When the instrument is connected to a PC through the USB port, the latter acts as “Host”, whereas the former acts as “Device”.

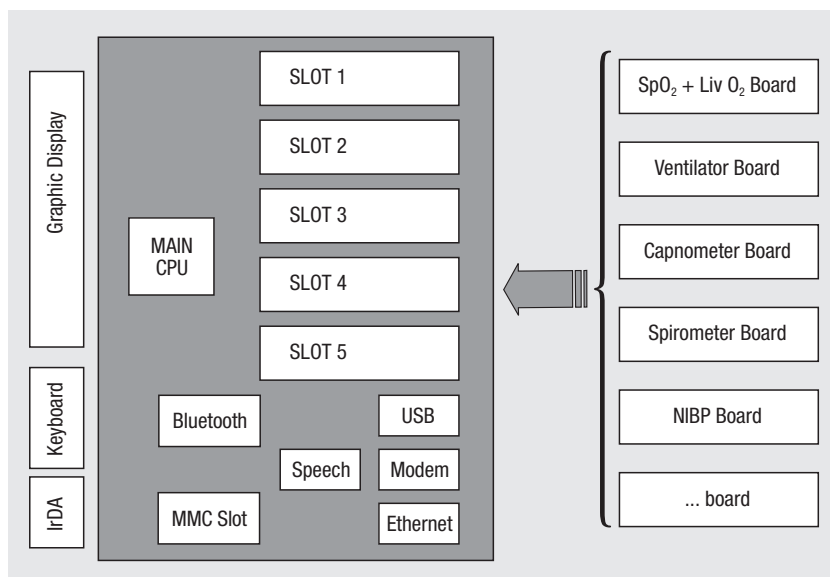

Fig. 1 | Block diagram of the telemedicine instrument.

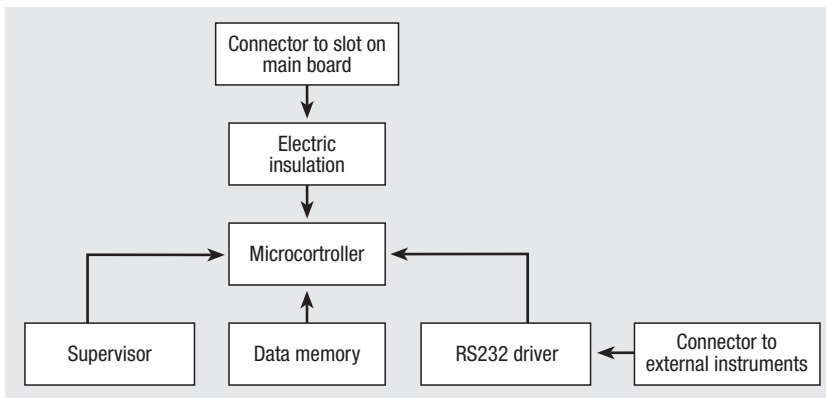

Fig. 2 | Block diagram of a generic measuring/interface board.

For this reason, the physical connector of the instrument USB port is of the “B receptacles” type.

IrDA interface

The IrDA interface has two main functionalities. First, it allows sending commands to the instrument through the remote control: that could be of great convenience for patients with difficulties in movements (or, even worse, always in bed), because it could be uncomfortable for them to reach the instrument keyboard. Second, the IrDA interface allows connection to a notebook, PDA, or mobile phone, equipped with IrDA interface.

To realize communication with the remote control, the basic component is an IrDA encoder/decoder. This component transforms the signals from the IrDA to the UART format. It typically works at 9600 baud. Furthermore, to realize possible interface with a notebook, PDA, and mobile phone, an IrDA stack controller is used, produced by Microchip. This component includes all the IrDA protocol layers, which are necessary to communicate with the above-mentioned devices. The transmission speed is 115200 baud.

Bluetooth interface

Bluetooth is currently the most promising technology for wireless communication in an indoor environment. The advantage of Bluetooth compared to IrDA (or infrared technology in general) is that the former does not require being in line of sight: within its communication range, also the presence of an obstacle (such as a wall) does not prevent communication, differently from infrared.

Moreover, Bluetooth technology performs frequency hopping over 79 channels, each displaced by 1 MHz (in the ISM band, between 2.402-2.480 GHz), at 1600 hops per second. Bluetooth protocols also implement other solutions related to security of the communication, such as data encryption and user authentication. All these features can be particularly convenient when managing sensitive data such as clinical ones.

In the instrument, Bluetooth functionality was obtained through an OEM module with Bluetooth qualification. The module is interfaced to the main CPU through a serial port, and communication

occurs through a high level protocol implemented on both sides.

Speech unit

The speech unit can provide to the patient some vocal information about the instrument state, possibly related to some commands selected by the patient through the remote control of the instrument. Moreover, the health professional (GP, or specialist), which has seen the patient’s data through the Internet, can also send him a message related to the patient’s current state of health. Through the speech utility, the patient can listen to the message.

The core of the speech unit is a DSP audio processor: a stream of bit in MPEG format (MP3), in input to this component, is transformed in analog format. After proper filtering and processing the related signal can drive an acoustic speaker.

Other components of the main board

The main board is also equipped with connectors to a nine buttons keyboard, and to a graphic display (240×64 pixels). A slot is also present for MultiMedia or Secure Digital card, which allows memory expansion to several megabytes.

Measuring and interface boards: general concepts

The main board is also equipped with five slots for insertion of the measuring and interface boards. The former are the blood oxygen saturation board and the ventilation board, whereas the latter are the spirometer board, the capnometer board and the non-invasive blood pressure (NIBP) board. Through the interface boards our instrument acts as a digital recorder, thus collecting the data measured by the connected external instruments. It is worth noting that the instrument slots are equivalent, and hence there is not a fixed slot for each measuring and interface board: one board can be inserted in any of the five slots. That means maximum flexibility in the configuration of the instrument.

The main components, common to both measuring and interface boards, are reported in *Figure 2*. The electric insulation of the measuring/interface board from the main board guarantees separation among

our instrument and the external instruments connected. Thanks to this architecture, an abnormal event in the main board (peak of voltage or current) will not propagate to the measuring/interface board, and *vice-versa*. This is important for both the safety of all the instruments and, especially, of the patient. Furthermore, the separation between two external instruments connected to our instrument is double: a first separation is present between the interface board related to one external instrument and the main board, and a second separation between the latter and the interface board related to the other external instrument. Insulation is realized through fast optoisolators for data lines, and through DC/DC converters.

The core of the measuring/interface board is a microcontroller (PIC18F6620 component from Microchip), equipped with Flash and RAM memory, and several peripherals such as timers, serial ports, A/D converters, PWM signal generators. An additional memory for data storage (FRAM type) is also present.

The RS232 driver is necessary in the case that a conversion from TTL/CMOS level to RS232 level (0-5V to $\pm 9V$) is required for connection to the external instrument. In the case that the external instrument has outputs already in TTL/CMOS format, the RS232 driver is excluded through a proper jumper. A proper connector is present on the board for physical connection to the external instrument. Finally, several components are present for protection from abnormal electrical events and for EMI reduction, similarly to what already reported for the main board.

The connection between the main board and the measuring/interface boards is driven by the main CPU: at prescribed intervals, it sends sequentially to the boards a query, asking for board state, and for possible presence of data coming from the external instruments. Depending on the answers from the boards, the main CPU performs the necessary actions, such as transmission of data collected from the boards.

Blood oxygen saturation board

Although the reported architecture is common for all the measuring/interface boards, some differences are present between the different boards. A special board is the blood oxygen saturation measuring board. In fact, it includes an OEM module from Nellcor, MP506 (accuracy: ± 2 units for saturation in 1-100% range, ± 3 units for pulse rate in 20-300 bpm range).

By integrating this module, it is not necessary to connect to an external pulse oximeter to get blood oxygen saturation and pulse rate. The patient only has to wear a pulse oximetry probe (a finger probe, typically), which is connected directly to one connector of the saturation board.

A second connector is present in the saturation board, since it also allows connection to an O_2 unit for measurement of the residual oxygen level.

Ventilation board

Another special board is the ventilation board. This board allows connection to all the ventilators, also those missing any electrical communication port. In fact, an air flow sensor is inserted into the patient's circuit, *i.e.* inside the tube that brings air from the ventilator to the patient. This flow sensor provides a resistance to the air flow, through a proper lumen reduction. The flow sensor is then connected to the ventilation board, where a differential pressure sensor measures the pressure difference at the extremities of the flow sensor. Since the flow resistance is fixed and known, an estimation of both expiratory and inspiratory patient's air flow is obtained from the pressure difference. Other derived parameters, such as the total volume of air inspired in a respiratory cycle, are then obtained at firmware level.

The ventilation board is indeed the most unusual board among those developed so far: in fact, it is a mixture of electronic components and connection lines, and of mechanic components and hydraulic tubes (*Figure 3*).

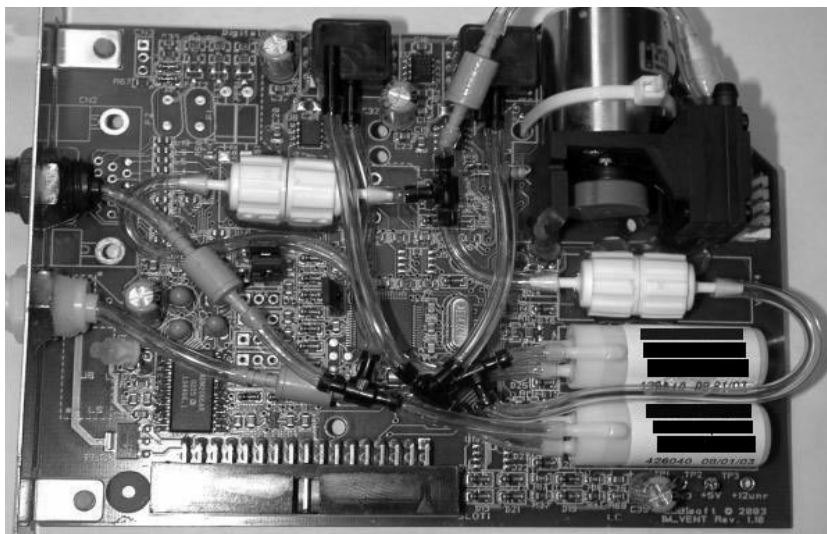

Fig. 3 | *The ventilation board.*

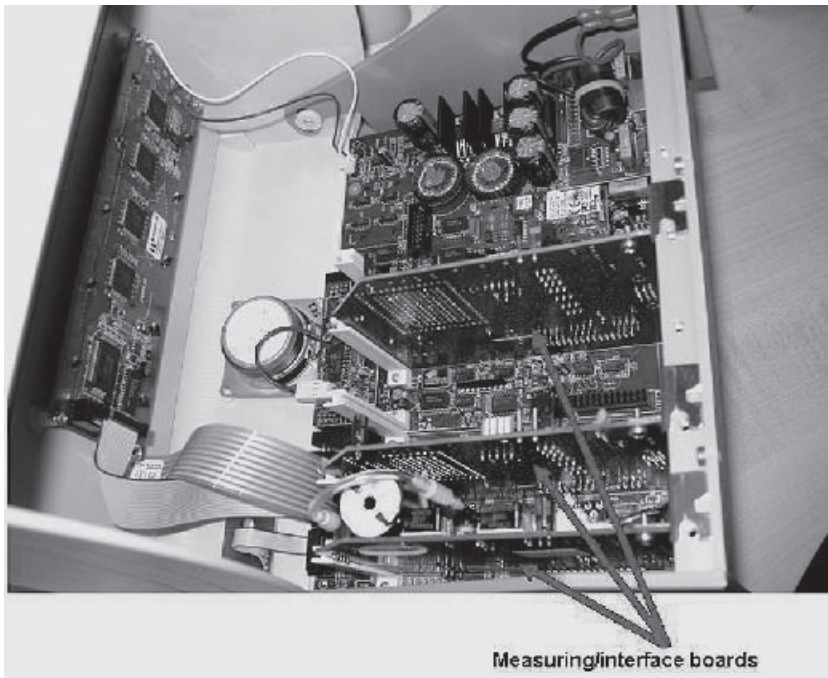

Fig. 4 | Internal view of the instrument, showing some measuring/interface boards inserted vertically in the slots.

RESULTS

Assessment of performance of the measuring/interface boards

The instrument was extensively tested in different configurations, both with one measuring/interface board only, and with several boards installed at the same time (up to five, accordingly to the number of slots in the main board). In fact, it is easy to open the instrument case, and insert the boards in the slots, as depicted in *Figure 4*.

We established some test procedures to evaluate the performance of the boards. To test the saturation board, we performed test sessions lasting 18 hours, where the instrument measured and stored a new sample of oxygen saturation and of pulse rate every second (the acquisition protocol can be selected within a wide range of different protocols).

In the first instants of the test session, the instrument was connected to a pulse oximetry simulator (Nellcor, SRC-MAX). First, the simulator value for saturation was set to 75%. The pulse rate was set to 60 bpm. A technician checked that the instrument displayed the values provided by the simulator, with error not higher than 1 unit for saturation and 3 bpm for pulse rate. Second, the test was repeated with simulator values equal to 90% for saturation and 200 bpm for pulse rate, with the same acceptance criteria as before. Next to the end of the 18 hours test session, the two tests with the simulator were repeated. After test session end, results of the session were further controlled through a simple data visualization tool on a PC: the instrument was connected to the PC, and data downloaded and displayed. The total number of acquired samples for both saturation and pulse rate had to be as expected (3600 samples per hour \times 18 hours = 64800 samples).

Test sessions were also performed for the evaluation of the ventilation board. To this purpose, we connected a commercial pulmonary ventilator to the ventilation board through the air flow sensor, and completed the experimental setup with a three liters balloon, simulating the patient (*Figure 5*). We imposed on the ventilator 15 breathes per minute, and air volume of 8 liters per minute. Then, we started the test session; again, each session lasted 18 hours. At the beginning of the session, the technician checked on the instrument display that the respiratory rate and the inspiratory/expiratory volume were as expected. We accepted errors not higher than 5%. At the end of the session, collected samples were again checked on the PC, as well as the number of samples (15 samples per min \times 60 min \times 18 hours = 16200 samples).

The interface boards for connection to a spirometer, a capnometer and a NIBP device were tested with similar procedures (not reported here for brevity). It must be noted, however, that in these cases our instrument only performs the acquisition of the measures provided by the external instruments. Therefore, possibilities of problems and abnormal behaviour were lower than in the saturation and ventilation board.

Assessment of reliability of remote transmission through the Internet

A critical element among the instrument functionalities is the remote transmission of the data through the Internet. In fact, due to the integrated TCP/IP protocol, the instrument can connect directly to a server over the Internet, and hence the collected data can be easily made accessible through



Fig. 5 | *Experimental setup for testing of the ventilation board (respiratory balloon, our instrument, a commercial pulmonary ventilator, from left to right, respectively).*

a Web application. The data transmission can occur in two different modes: automatic mode, where the instrument transmits at a prescribed time, and manual mode, where transmission is started by pressing a proper button on the keyboard.

The communication sessions were proved to be robust, and usually were performed correctly. The instrument was configured to perform up to three attempts of connection and transmission. In the case of any problem, however, an error code is stored within the instrument memory, and made accessible through the display. Examples of possible errors that were experimented during the tests are reported in *Table 1*. It is worth noting that more refined error information is stored into a log file, which is transmitted to the server together with the data files. That allows remote diagnosis of technical problems possibly occurred. Afterwards, appropriate actions can be performed, if necessary: since communications between the instrument and the server is designed to be bidirectional, it is possible to send to the former

a new setup file, thus changing some instrument parameters, and also a new firmware version for both the main CPU and the microcontroller of the measuring/interface boards.

Summary of test results

The results of all the tests performed over the instrument units produced between 2003 and 2005 are reported in the *Table 2*. Apart for 2003 where only a few units were produced, in 2004 and 2005 a significant number of tests were performed over the produced units. It can be noticed that the percentage of test failure (score) was already low in 2004, and it decreased in 2005.

Preliminary trials on patients

Some preliminary tests have been performed on fifteen patients with amyotrophic lateral sclerosis. The patients were informed about the aim of the tests, and gave their consent. The patients generally expressed positive comments about easiness in the

Table 1 | *Possible errors during the communication between the instrument and the Web server*

Error code	Meaning
1	The instrument has been switched off during the initialization of the communication (before connection to the server)
2	Errors in the initialization of the internal modem
3	Problems in the authentication to the Internet POP
4	Problems in resolving the IP address of the destination (the server)
-1	Connection timeout: the instrument is contacting the server, that is present on the Internet, but it does not answer within the expected time intervals
-2	Loss of connection: the instrument has connected regularly to the server, but connection has been interrupted for some reasons
-3	Request for connection closure by the server: the server has probably received unreliable data packets from the instrument, and hence decided to stop the connection
-4	Impossible to connect to the server (for unknown reason)
-5	Timeout during socket closure: the communication has occurred regularly, but during the closure of the connection an error has been detected

Table 2 | Summary of test results on the instrument units produced in 2003-2005

	2003	2004	2005
Non conformity during tests	0	28	6
Total of tests	12	1838	1796
Score	0.0%	1.5%	0.3%

use of the instrument and in making the proper settings, thanks also to the big display. Furthermore, they particularly appreciated the presence of the remote control, which made comfortable some operations from the bed, such as decreasing the intensity of display light and stopping the acoustic warning at sleep time. All the patients transmitted to the server several data, which the health professionals, with proper permissions, displayed through the instrument Web application. An example of data display for blood oxygen saturation and pulse rate is reported in *Figure 6*. It must be noted that all the patients were using a pulmonary ventilator. Related clinical parameters are reported in *Table 3*.

Table 3 | Parameters of pulmonary ventilation in the studied subjects. For each parameter the mean over a monitoring session was computed in each subject; then, mean and standard deviation (SD) over the group were computed.

	Mean	SD
Inspiratory volume (ml) *	538	55.4
Expiratory volume (ml) *	530	51.0
Respiratory rate (bpm)	15.0	4.4
Maximum inspiratory flow (ml/s)	534	138
Maximum expiratory flow (ml/s)	563	152
Ventilation (l/min)	8.1	2.3
Maximum inspiratory pressure (cmH ₂ O)	19.2	7.2

* during one breath.

DISCUSSION

We developed a medical instrument for home monitoring of patients with respiratory diseases. Indeed, several respiratory diseases can benefit from home monitoring solutions, such as asthma or obstructive pathologies [9, 10], but also less common problems

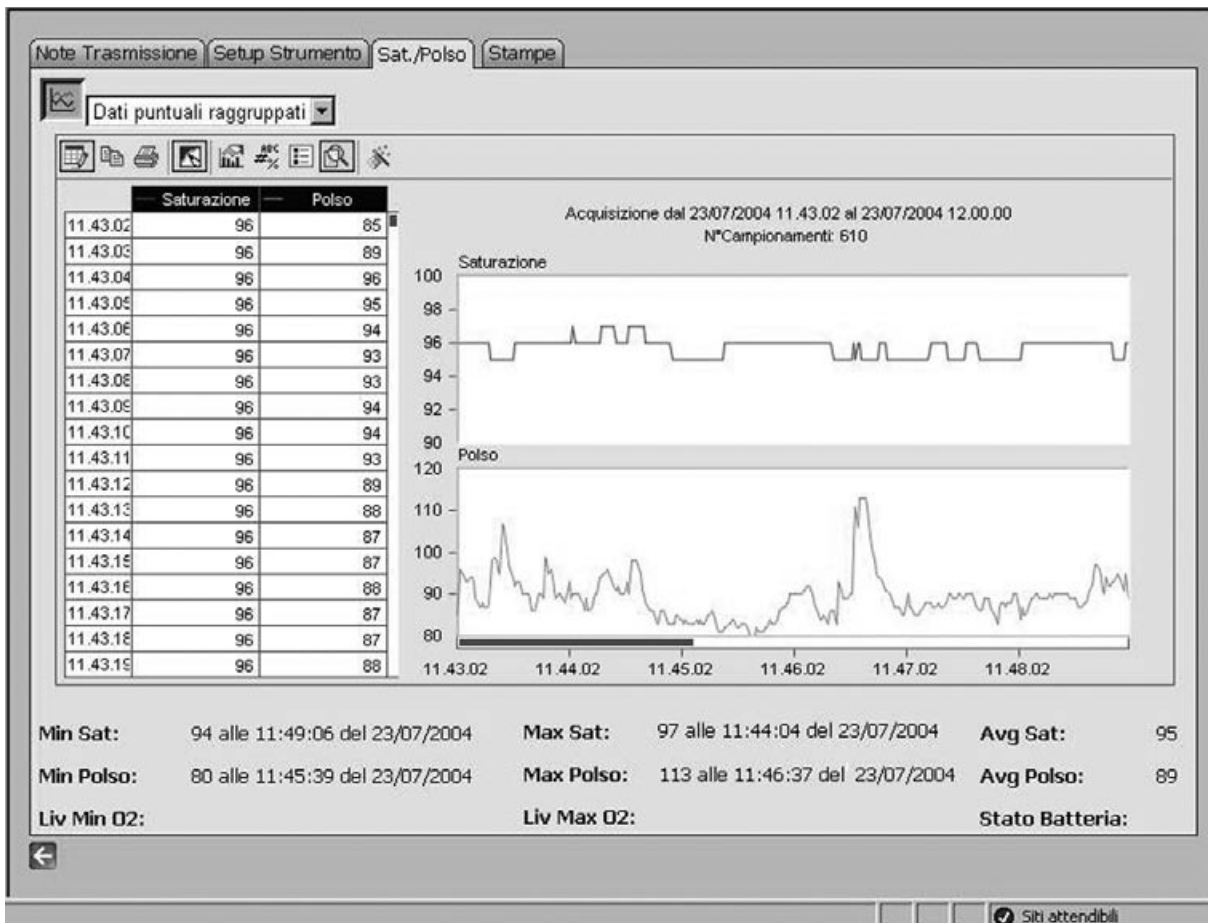
**Fig. 6** | Portion of the Web page in the instrument Web application displaying blood oxygen saturation and pulse rate data.

such as sleep apnoea [11] or post-operative recover after lung transplantation [12].

The instrument is a medical device compliant to the Directive 93/42/EEC. Since it is an active device for diagnostic purposes through non-invasive measurements of physiological parameters for short time intervals, it was allocated in Class IIa.

In several home monitoring platforms, transmission of clinical data from the patient's home to the central database and, generally, communication between the patient and the health professionals, requires a personal computer or a similar device, such as a notebook, palmtop computers or PDAs [9, 11, 13]: typically, the medical instruments collect the data of interest and download them to the personal computer (via serial port or even wirelessly), and finally they are sent to the remote site. We can claim that direct, independent functionality of remote data transmission is still quite rare in a medical instrument, except for traditional methods, such as transtelephonic transmission used especially for ECG monitoring [14], which however has several limitations and usually requires patient's intervention. Conversely, our instrument is able to directly transmit the collected clinical data to the remote central database. In one of our previous home monitoring instruments, the transmission occurred through the telephonic network in a point-to-point configuration. That required several modems connected to the server at the remote site. In fact, since communication between modems is one-to-one, a sufficient number of modems must be present remotely to fulfil possible contemporary calls from the patients' homes. Moreover, a long distance call could be necessary depending on the location of the patient's home. These problems are overcome in the presented new instrument, where the included TCP/IP protocol allows transmission of data through the Internet. Here, the modem call is not to the remote server but simply to a local Internet POP, and at the remote site a Web server is present with sufficient bandwidth, but with no need of any array of modems. It is worth noting that the data transmission can be both manual (by pressing a proper button) and automatic, at prescribed time intervals: in the second case, no attention is required from the patient.

The instrument has been designed to act as a digital recorder of several clinical parameters. Some are measured directly, whereas other parameters are collected from external instruments. At the moment, the number of external instruments which can be connected to ours is limited. In particular, some instruments of interest in the monitoring of respiratory diseases have been considered (the most relevant are one spirometer, one capnometer, and one NIBP measuring device). On the other hand, any pulmonary ventilator can be interfaced, since the interface is realized at the patient's circuit level, and this is another advantage of our instrument. Furthermore, due to the design of the instrument, interfacing different external instruments for future applications will be straightforward: new boards

to be inserted into slots have to be developed only, without affecting the main board and the other instrument components. Therefore, other instruments for ambulatory or domiciliary use will be possibly connected, such as an ECG monitor, a glucometer or coagulation monitoring device, for possible application of the home monitoring system in different pathologies, such as diabetes [15]. In fact, we believe that several chronic diseases could benefit from home monitoring of some key parameters, especially if the system is designed to be automatic for patients and with easy access to the measured data for the health professionals.

The instrument architecture, based on slots for insertion of the measuring/interface boards, allows flexibility and modularity: for each patient, only the boards needed for telemonitoring of his clinical condition can be mounted, and that can lead to decreased system costs. The cost of telemedicine systems is in fact a crucial issue. The question about cost-effectiveness of telemedicine was posed already more than one decade ago. In fact, in [16], it was claimed that high amount of moneys were invested in telemedicine projects, but the cost-effectiveness was not proved also due to the difficulty in the estimation of telemedicine costs. To this purpose, specific economic models have been developed, in the attempt to overcome the main difficulties related to the economic evaluation of telemedicine, such as underlying technology changing extremely rapidly and sample size of the telemedicine trials often small [17]. Despite of these efforts, economic evaluation of telemedicine remain difficult, as recently noticed in [18]. Nonetheless, some reviews about the cost-effectiveness of telemedicine experiences were attempted. In [19], more than 500 articles on telemedicine were considered, and the conclusion was that no sufficient evidence was provided about cost effectiveness. However, it must be noticed that only a small percentage of the considered works (around 10%) provided economic considerations and hence were studied in the review. Furthermore, some other reviews provided different conclusions. In the already mentioned study [2], 66 articles were identified that included economic considerations of telemedicine experiences and comparison with a non-telemedicine alternative, and more than half of such experiences suggested that telemedicine had advantages over the alternative approach, also in economic terms. Similar results were also found in a more recent work by the same authors [20].

In conclusion, the cost-effectiveness of telemedicine is still a subject for debate, but some positive evidences have been already shown. Our personal feeling is that telemedicine, and especially home telecare, will gain increasing diffusion in the next years, due to the concomitant factors of decreased cost for technology and ageing of population.

Received on 2 January 2007.

Accepted on 5 March 2007.

References

1. Mun SK, Turner JW. Telemedicine: emerging e-medicine. *Annu Rev Biomed Eng* 1999;1:589-610.
2. Hailey D, Roine R, Ohinmaa A. Systematic review of evidence for the benefits of telemedicine. *J Telemed Telecare* 2002;8(Suppl 1):1-30.
3. Ackerman M, Craft R, Ferrante F, Kratz M, Mandil S, Sapci H. Telemedicine/telehealth: an international perspective. Telemedicine technology. *Telemed J E Health* 2002;8:71-8.
4. Tachakra S, Wang XH, Istepanian RS, Song YH. Mobile e-health: the unwired evolution of telemedicine. *Telemed J E Health* 2003;9:247-57.
5. Mahmud K, Le Sage K. Telemedicine: a new idea for home care. *Caring* 1995;14:48-50.
6. Scalvini S, Volterrani M, Giordano A, Glisenti F. Boario home care project: an Italian telemedicine experience. *Monaldi Arch Chest Dis* 2003;60:254-7.
7. Takizawa M, Sone S, Hanamura K, Asakura K. Telemedicine system using computed tomography van of high-speed telecommunication vehicle. *IEEE Trans Inf Technol Biomed* 2001;5:2-9.
8. Morlion B, Verbandt Y, Paiva M, Estenne M, Michils A, Sandron P, Bawin C, Assis-Arantes P. A telemanagement system for home follow-up of respiratory patients. *IEEE Eng Med Biol Mag* 1999;18:71-9.
9. Finkelstein J, Hripsak G, Cabrera M. Telematic system for monitoring of asthma severity in patients' homes. *Medinfo* 1998;9:272-6.
10. Mair FS, Wilkinson M, Bonnar SA, Wootton R, Angus RM. The role of telecare in the management of exacerbations of chronic obstructive pulmonary disease in the home. *J Telemed Telecare* 1999;5(Suppl 1):S66-7.
11. De Molles DA, Sparrow D, Gottlieb DJ, Friedman R. A pilot trial of a telecommunications system in sleep apnea management. *Med Care* 2004;42:764-9.
12. Finkelstein SM, Snyder M, Edin-Stibbe C, Chlan L, Prasad B, Dutta P, Lindgren B, Wielinski C, Hertz MI. Monitoring progress after lung transplantation from home-patient adherence. *J Med Eng Technol* 1996;20:203-10.
13. Lin YH, Jan IC, Ko PC, Chen YY, Wong JM, Jan GJ. A wireless PDA-based physiological monitoring system for patient transport. *IEEE Trans Inf Technol Biomed* 2004;8:439-47.
14. Saarel EV, Stefanelli CB, Fischbach PS, Serwer GA, Rosenthal A, Dick M 2nd. Transtelephonic electrocardiographic monitors for evaluation of children and adolescents with suspected arrhythmias. *Pediatrics* 2004;113:248-51.
15. Klonoff DC. Diabetes and telemedicine: is the technology sound, effective, cost-effective, and practical? *Diabetes Care* 2003;26:1626-8.
16. Scott L. Will healthcare accept the "virtual" doctor? Maybe, but telemedicine's cost-effectiveness remains in question. *Mod Healthc* 1994;24:34-41.
17. McIntosh E, Cairns J. A framework for the economic evaluation of telemedicine. *J Telemed Telecare* 1997;3:132-9.
18. Reardon T. Research findings and strategies for assessing telemedicine costs. *Telemed J E Health* 2005;11:348-69.
19. Whitten PS, Mair FS, Haycox A, May CR, Williams TL, Hellmich S. Systematic review of cost effectiveness studies of telemedicine interventions. *BMJ* 2002;324:1434-7.
20. Hailey D, Ohinmaa A, Roine R. Study quality and evidence of benefit in recent assessments of telemedicine. *J Telemed Telecare* 2004;10:318-24.